



Features of the power supply:

- power output 2,5A/48VDC*
- universal AC input voltage range 90÷264V
- built-in active power factor correction circuit (PFC)
- high efficiency 90%
- LED optical signalisation
- standby power <0,5W
- efficiency level: V
- protections:
 - SCP short-circuit protection
 - overvoltage protection (AC input)
 - overload (OLP)
- warranty – 2 year from the production date

1. Technical description.

1.1. General description.

Stabilized DC power supply is intended for supply CCTV cameras that require stabilised voltage of **48V DC**. The unit has a cable with a DC5.5/2.1 plug. The power supply unit is protected against short-circuit, overload and overvoltage.

1.2. Technical parameters.

Supply voltage	90 ÷ 264V AC 50÷60Hz
Current consumption	0,6A@230V AC max.
Supply power	120W max.
Efficiency	90%
Power factor PF	>0,95 @230V AC
Output voltage	48V DC
Output current $t_{AMB}<30^{\circ}C$	2,5A - refer to graph 1.
Output current $t_{AMB}=40^{\circ}C$	1,75A - refer to graph 1.
Ripple voltage	250mV p-p max.
Short-circuit protection SCP	electronic, automatic recovery
Overload protection OLP	150-200% of power supply, automatic recovery
Optical signalisation	LED – presence of DC voltage
Operation conditions	temperature $-10^{\circ}C \div +40^{\circ}C$ relative humidity 20%...90%, without condensation
Dimensions (LxWxH)	172 x 73 x 34 [mm]
Net/gross weight	0,75kg/0,85kg
Protection class PN-EN 60950-1:2007	I (first)
Length of DC cable	1,5m + plug DC5,5/2,1 female
Length of AC cable	1,5m + mains plug
Storage temperature	$-20^{\circ}C \dots +60^{\circ}C$

* In order to extend the life of the power supply, the load current of 1,75A is recommended.

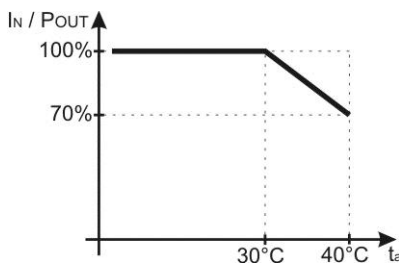

Graph 1.
 Relation between output current and ambient temperature (instantaneous load).

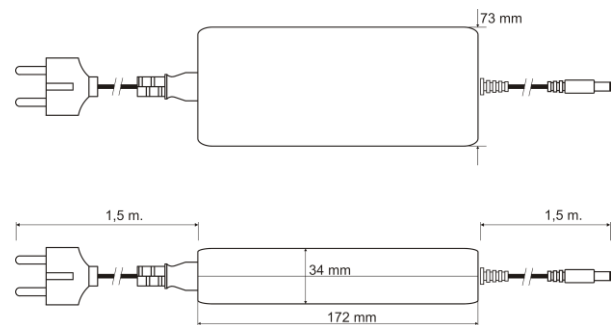

Fig.1. Dimension of power supply.

* Refer to graph 1

1.3. Accessories.

For power supplies are available accessories - cable adapter. For details –visit www.pulsar.pl.

2. Installation.

2.1. Requirements.

The power supply shall be mounted by the qualified installer having appropriate (required and necessary for a given country) permissions and qualifications for connecting (operating) low-voltage installations. The power supply shall be mounted in closed rooms, according to the environment class II, of the normal air humidity (RH=90% max. without condensation) and the temperature within the range from -10°C to +40°C.

The power supply shall be mounted in a close casing (a cubicle, a terminal device) and in order to fulfill LVD and EMC requirements the rules for power supplies, encasing and shielding shall be observed according to application.

2.2. Installation procedure.

1. Connect the DC output to the load/loads.
2. Connect the power supply unit to the AC line. The power supply has to be installed in such way to keep the air flow around the supply unit.
3. After tests and operation control are performed, the casing (cubicle) shall be closed etc.

3. Maintenance.

Any and all maintenance operations may be performed following the disconnection of the power supply from the power network. The power supply does not require any specific maintenance procedures, however, in the case of significant level of dust, it should be cleaned with the compressed air.



WEEE MARK

According to the EU WEE Directive – It is required not to dispose of electric or electronic waste as unsorted municipal waste and to collect such WEEE separately.

Pulsar

Siedlec 150, 32-744 Łapczyca, Poland
Tel. (+48) 14-610-19-40, Fax. (+48) 14-610-19-50
e-mail: biuro@pulsar.pl, sales@pulsar.pl
http:// www.pulsar.pl, www.zasilacze.pl