



PSACH 01246

v.1.0

PSACH 24VAC/6A/1x6A
AC power supply for 1 rotating camera, ABS enclosure

EN

Edition: 3 from 02.09.2015

Supersedes the edition: 2 from 12.12.2013



Features:

- the 24V AC/6A or 27V AC/ 5,5A power output for powering camera
- power voltage 230V AC
- protections:
 - SCP short-circuit protection
 - OLP overload protection
 - OHP overheat protection
 - against tampering
- IP65 ABS, hermetic enclosure
- warranty – 2 year from the production date

Sample power supply unit for rotating camera supplied with AC voltage.

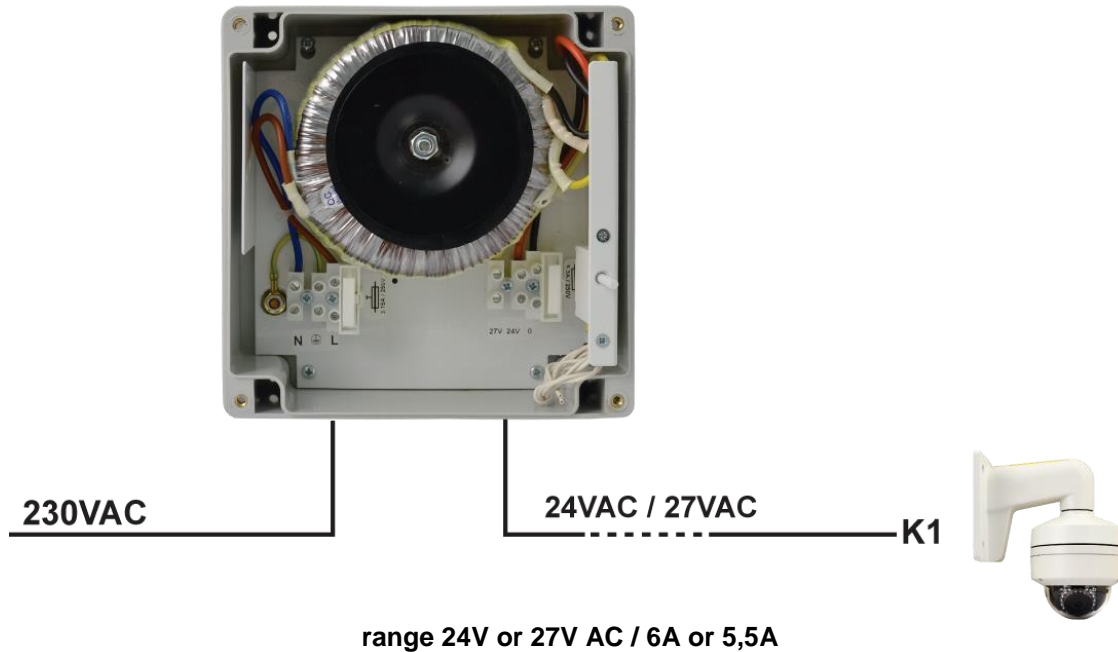

range 24V or 27V AC / 6A or 5,5A

Schematic diagram of a power supply.

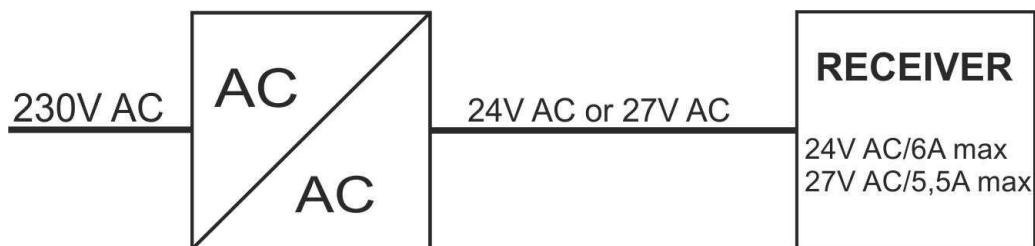

CONTENTS:

1. Technical description.
 - 1.1 General description
 - 1.2 Block diagram
 - 1.3 Description of PSU components
 - 1.4 Specifications
2. Installation.
 - 2.1 Requirements
 - 2.2 Installation procedure
3. Operating status indication.
 - 3.1 Technical output
4. Operation and use.
 - 4.1. Overload or short circuit at the PSU output
 - 4.2. Maintenance

1. Technical description.

1.1. General description.

The AC/AC PSU intended for supplying devices requiring voltage AC of **24V AC** (U1= 24V AC/ U2= 27V AC) and total capacity of **6A@24V AC**. It features protections: short-circuit (SCP), overload (OLP), transformer overheat (OHP). The PSU is housed in a ABS enclosure that features a microswitch indicating unwanted opening of the front door (faceplate).

1.2. Block diagram.

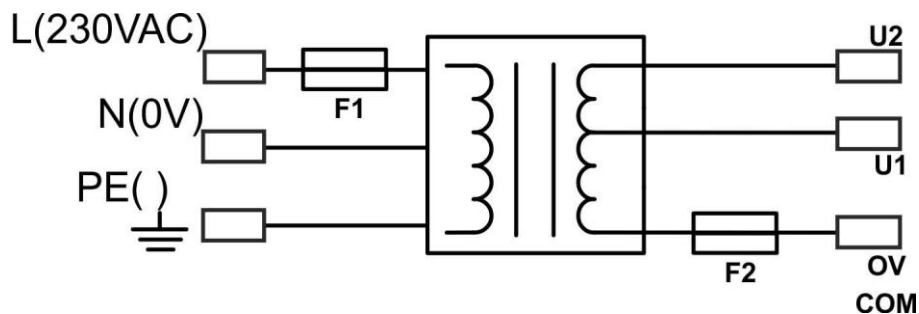



Fig.1. Block diagram of the PSU.

1.3. Description of PSU components.

Tab.1. Elements of the power supply unit.

Element no. [Fig. 2]	Description
[1]	Isolation transformer
[2]	TAMPER, tampering connector (NC)
[3]	AUX: U2-U1-0V secondary voltage connector, devices power supply (SEC)
[4]	F2 fuse in the secondary voltage circuit
[5]	F1 fuse in the power supply circuit (230V AC, PRI)
[6]	L-N connector 230V/AC,  PE protection connector

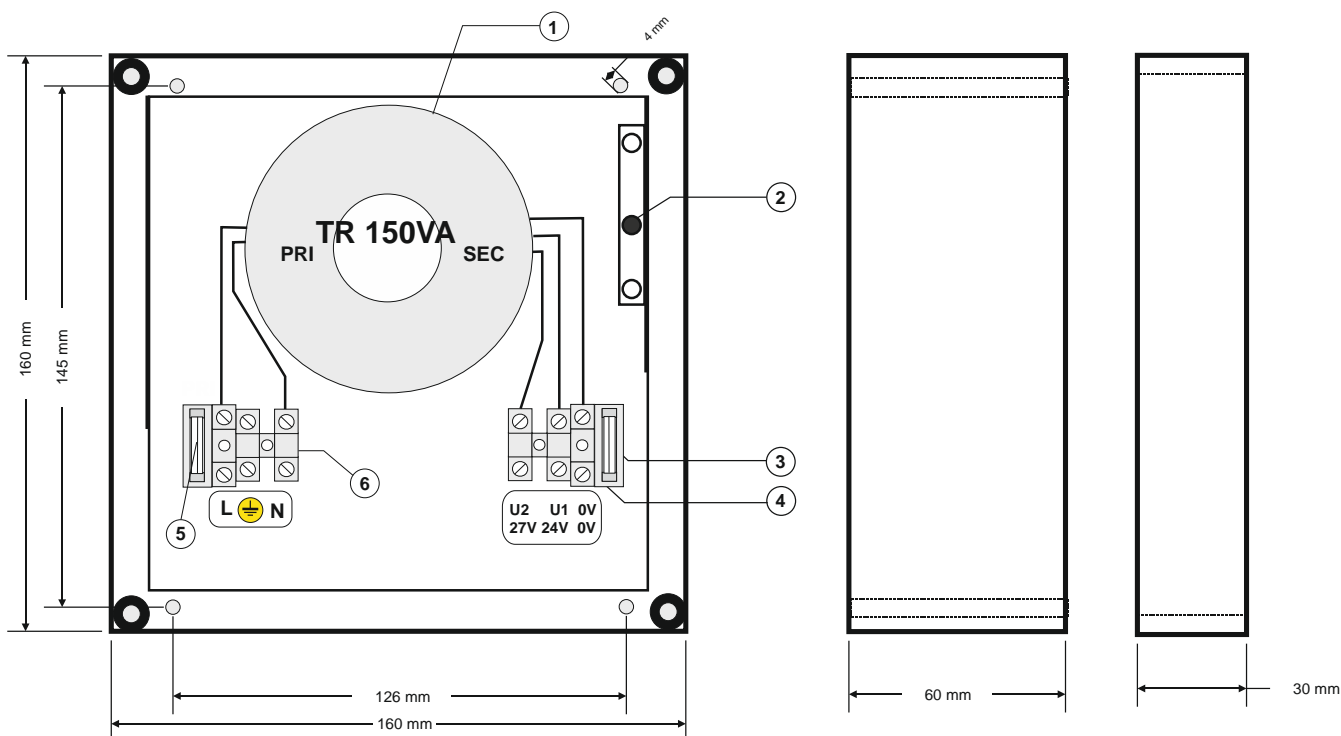

Fig.2. The view of the PSU.

1.4 Specifications:

- electrical specifications (tab.2)
- mechanical specifications (tab.3)
- operation safety (tab.4)
- operating specifications (tab.5)

Electrical specifications (tab. 2).

Mains supply	230V AC (-15%/+10%)
Current consumption	0,75A max.
Power frequency	50 Hz
Power of the S PSU	150VA max.
Output voltage	U1: 23÷28V AC (100% load ÷ 0% load) U2: 25,5÷31,5V AC (100% load ÷ 0% load)
AUX output current	6A@24V AC max. or 5,5A@27V AC max.
Short-circuit protection SCP	1x T 6,3A glass fuse - glass fuse damage requires fuse-element replacement
Overload protection OLP	circuit AC 24V: 1x T 6,3A circuit AC 230V: 1x T 3,15A
Overheat protection OHP	inside transformer
Sabotage protection: - TAMPER output indicating enclosure opening	- microswitch, NC contacts (enclosure closed), 0,5A@50V DC (max.)
F1 fuse	T 3,15A/250V
F2 fuse	T 6,3A/250V

Mechanical specifications (tab. 3).

Enclosure dimensions	160 x 160 x 90 (WxHxD) [mm] (+/- 2)
Fixing	126 x 145 x Φ 4 x 4szt (WxH)
Net/gross weight	2,45/2,53 kg
Enclosure	ABS, IP65, light grey
Closing	Cheese screw x 4 (at the front)
Connectors	Power supply: Φ 0,63÷2,50 (AWG 22-10) Outputs: Φ 0,63÷2,50 (AWG 22-10), TAMPER output: wires, 25cm
Notes	The enclosure has a removable mounting board with the PSU systems.

Operation safety (tab.4).

Protection class PN-EN 60950-1:2007	I (first)
Protection grade PN-EN 60529: 2002 (U)	IP65 Glands installation required: M12 (Φ 3-6,5mm) x2 M16 (Φ 4-8mm) x2
Electrical strength of insulation: - between input (network) circuit and output circuits of the PSU (I/P-O/P) - between input circuit and PE protection circuit (I/P-FG) - between output circuit and PE protection circuit (O/P-FG)	3000V AC min. 1500V AC min. 500V AC min.
Insulation resistance: - between input circuit and output or protection circuit	100 M Ω , 500V/DC

Operating specifications (tab.5).

Operating temperature	-25°C...+40°C
Storage temperature	-25°C...+60°C
Relative humidity	10%...90% without condensation
Vibrations during operation	unacceptable
Impulse waves during operation	unacceptable
Direct insolation	unacceptable
Vibrations and impulse waves during transport	PN-83/T-42106

2. Installation.

2.1 Requirements

The AC/AC power supply is to be mounted by a qualified installer, holding relevant permits and licenses (applicable and required for a given country) for 230V/AC interference and low-voltage installations. The unit should be mounted in confined spaces, in accordance with the 2nd environmental class, with normal relative humidity (RH=90% maximum, without condensation) and temperature from -25°C to +40°C (table 5). The PSU shall work in a vertical or horizontal position.

Before mounting the PSU module, perform a load balance. During normal operation, total current drawn by the receivers cannot exceed **I=6A@24V AC**.

As the PSU is designed for a continuous operation and is not equipped with a power-switch, therefore an appropriate overload protection shall be guaranteed in the power supply circuit. Moreover, the user shall be informed about the method of unplugging (usually through assigning an appropriate fuse in the fuse-box). The electrical system shall follow valid standards and regulations.

2.2 Installation procedure.

- 1). Before installation, make sure that the voltage in the 230V power-supply circuit is cut off.
- 2). Mount the glands in the enclosure, considering the diameter of power supply and receivers wires. Mind the location of the battery and additional equipment.
- 3). Mount the PSU in a selected location and connect the wires.
- 4). Connect the power cables to the L-N terminals. Connect the ground wire to the terminal marked by the earth symbol – “⊕”. Use a three-core cable (with a yellow and green PE protection wire) to make the connection. Lead the cables to the appropriate terminals of the connection board through the bushing.



The shock protection circuit shall be performed with a particular care, i.e. the yellow and green wire coat of the power cable shall stick to one side of the terminal marked with the '⊕' earth symbol in the PSU enclosure. Operation of the power supply without a properly made and fully operational shock protection circuit is **UNACCEPTABLE!** It can result in device damage or an electric shock.

- 5). Connect the conductors of consumers to the terminals U1-0V and/or U2-0V of the terminal box on the power-supply unit (the balance of the power-supply load shall be performed).
- 6). Restore the mains power ~230V AC.
- 7). Once the tests and control operation have been completed, close the PSU.

3. Operating status indication.

3.1 Technical outputs.

The PSU is equipped with indication outputs allowing transmitting the information of casing sabotage (casing opening).

- **TAMPER: output indicates opening the power-supply unit**, output as volt-free contacts which indicate power-supply unit door status, unit closed: NC, unit opened: NO.

4. Operation and use.

4.1 Overload or short circuit at the PSU output

The U1-U2-0V PSU outputs are protected against a short circuit with glass fuse.

If the PSU is loaded with current exceeding $\Sigma 6A@24V AC$ (110% for ÷ 150% of S power), there occurs the F2 and/or F1 fuse damage in the 230V AC circuit. In case of a failure, replace the fuse of the same parameters.

4.2 Maintenance.

Any and all maintenance operations may be performed following the disconnection of the PSU from the power supply network. The PSU does not require performing any specific maintenance measures. However, in case of a significant dust level, clean the interior with compressed air. In case of a fuse replacement, use one of the same parameters.

**WEEE MARK**

According to the EU WEE Directive – It is required not to dispose of electric or electronic waste as unsorted municipal waste and to collect such WEEE separately.

GENERAL WARRANTY CONDITIONS

1. Pulsar (the manufacturer) grants a two-year warranty for the equipment, counted from the device's production date.
2. The warranty includes free-of-charge repair or replacement with an appropriate equivalent (the selection is at the manufacturer's discretion) if the malfunction is due to the manufacturer, includes manufacturing or material defects, unless such defects have been reported within the warranty period (item 1).
3. The equipment subject to warranty is to be brought to the place where it was purchased, or directly to the main office of the manufacturer.
4. The warranty applies to complete equipment, accompanied by a properly filled warranty claim with a description of the defect.
5. Should the claim be accepted, the manufacturer is obliged to provide warranty repairs, at the earliest convenience, however not later than within 14 days from the delivery to the service centre of the manufacturer.
6. The repair period mentioned in item 5 may be prolonged, if there are no technical possibilities to carry out the repairs, or if the equipment has been conditionally accepted, due to the breaking warranty terms by the claimant.
7. All the services rendered by force of the warranty are carried out at the service centre of the manufacturer, exclusively.
8. The warranty does not cover the defects of the equipment, resulting from:
 - reasons beyond the manufacturer's control,
 - mechanical damage,
 - improper storage and transport,
 - use that violates the operation manual or equipment's intended use
 - fortuitous events, including lightning discharges, power failures, fire, flood, high temperatures and chemical agents,
 - improper installation and configuration (in defiance with the manual),
9. The warranty is void in any of the following circumstances:
 - construction changes
 - repairs carried out by any unauthorized service center
 - damage or removal of warranty labels
 - modifications of the serial number
10. The liability of the manufacturer towards the buyer is limited to the value of the equipment, determined according to the wholesale prices suggested by the manufacturer on the day of purchase.
11. The manufacturer takes no responsibility for the defects that result from:
 - the damaging, malfunctioning or inability to operate the equipment
 - defects that result from using the equipment outside its stated specifications and operating parameters failing to abide by the recommendations and requirements contained in the manual, or the use of the equipment.

Pulsar

Siedlec 150, 32-744 Łapczyca, Polska
Tel. (+48) 14-610-19-40, Fax. (+48) 14-610-19-50
e-mail: biuro@pulsar.pl, sales@pulsar.pl
http:// www.pulsar.pl, www.zasilacze.pl